

Regulatory Information Report

RPF24072

**Fire resistance test for an air duct passing
through a horizontal separating element –
Internal fire**

Issued to:	Firestop Centre Ltd
Test method:	AS1530.4-2014
Report Date:	15/08/2024
Valid till:	09/08/2028
Test number:	PF24072



Table of Contents

- 1.1 Document revision schedule 3
- 1.2 Signatories 3
- 2. Report Summary..... 4
- 3. General Information 6
 - 3.1 Testing Scope 6
 - 3.2 Contact Details..... 6
 - 3.3 Timeline 7
 - 3.4 Use of the Report..... 7
- 4. Specimen Description..... 8
 - 4.1 Supporting Construction..... 8
 - 4.1 Specimen 2 – TPS cable..... 13
 - 4.2 Specimen 3 – Supporting Steel Channel 15
 - 4.3 Specimen 4 – Supporting Steel Channel 17
 - 4.4 Specimen 5 – Access Hatch 19
- 5. Additional temperature measurements 22
- 6. Permissible variations to the tested specimen 23



1.1 Document revision schedule

Revision #	Date	Description
1	21/06/2024	Initial issue for Client review
2	10/07/2024	Issued to Client
3	31/07/2024	Drawings are amended
4	15/08/2024	Cover page amended

1.2 Signatories

Report	Name	Signature	Date
Prepared by:	Alex Kokorin		15/08/2024
Authorised by:	Andrew Bain (Authorized signatory)		15/08/2024



All tests reported herein
have been performed in
accordance with the
laboratory's scope of
accreditation

2. Report Summary

An 800 mm diameter circular air duct was installed vertically, penetrating a 120 mm reinforced concrete slab. The penetration was protected using a combination of FR board, slotted steel equal angles, and FIRESTOP Ultra Acrylic Sealant. The duct itself was protected with 38 mm thick Firestop DuctWrap-38, fixed using duct pins and plain aluminium tape for cut edges and joints.

A rectangular access hatch measuring 640 mm x 520 mm (L x W), one 2.5 mm² 2C+E TPS cable, and two supporting steel channels measuring 42 mm x 42 mm (W x H) were installed on the vertical surface of the duct. These components were protected by Firestop DuctWrap-38 and FIRESTOP Ultra Acrylic Sealant. The access hatch had additional FR board protection.

Test results - duct wrap protection

Structural adequacy	No Failure at 125 minutes
Integrity	No Failure at 125 minutes
Insulation	Failure at 26 minutes
Fire resistance level (FRL)	120/120/15

Test results – TPS cable

Structural adequacy	Not applicable
Integrity	No Failure at 125 minutes
Insulation	No Failure at 125 minutes
Fire resistance level (FRL)	-/120/120

Supporting Steel Channel - Test results

Structural adequacy	Not applicable
Integrity	No Failure at 125 minutes
Insulation	No Failure at 125 minutes
Fire resistance level (FRL)	-/120/120

Access Hatch - Test results

Structural adequacy	No Failure at 125 minutes
Integrity	No Failure at 125 minutes
Insulation	Failure at 36 minutes
Fire resistance level (FRL)	120/120/30

The conditions of the test complied with AS1530.4-2014 requirements.

There were no major observations related to the performance criteria during the test.

3. General Information

3.1 Testing Scope

Applicable Standards:

AS 1530.4-2014 Section 9 Air ducts – Internal fire

AS 1530.4-2014 Section 10 Service penetrations and control joints

Departures from Testing Method:

No departures from the testing method

Conditions of the test complied with AS1530.4-2014 requirements.

3.2 Contact Details

Accredited Testing Laboratory

Fire TS Lab - Passive Fire Inspection and Test Services Ltd

Accreditation Number - 1335

1/113 Pavilion Drive, Mangere, Auckland, 2022

New Zealand

Contact e-mail: tests@firelab.co.nz

Issued to:

Firestop Centre Ltd.

657 Great South Rd, Penrose, Auckland, 1061

New Zealand

Contact e-mail: info@firestopcentre.co.nz

3.3 Timeline

Testing date:

07/06/2024

Installation completion date:

05/06/2024

Termination of The Test:

The test was discontinued at 125 minutes.

3.4 Use of the Report

Regulatory information report was issued in addition to full test report PF24072. This provides the minimum information required for regulatory compliance.

The report is valid till 09/08/2028.

This report shall not be reproduced, except in full.

This report details the methods of construction, test conditions and the results obtained when the specific element of construction described herein was tested following the procedure outlined in AS 1530.4. Any significant variation with respect to size, constructional details, loads, stresses, edge or end conditions, other than that allowed under the field of direct application in the relevant test method, is not covered by this report.

Because of the nature of fire resistance testing and the consequent difficulty in quantifying the uncertainty of measurement of fire resistance, it is not possible to provide a stated degree of accuracy of the result.

The test results relate to the specimens of the product in the form in which they were tested. Differences in the composition or thickness of the product may significantly affect the performance during the test and may therefore invalidate the test results. Care should be taken to ensure that any product, which is supplied or used, is fully represented by the specimens, which were tested.

The specimens were supplied by the sponsor and the Laboratory was not involved in any of selection or sampling procedures.

The results of these fire tests may be used to directly assess fire hazard, but it should be recognized that a single test method will not provide a full assessment of fire hazard under all fire conditions.

4. Specimen Description

4.1 Supporting Construction

Separating element		
1.1	Item	Concrete Slab
	Aperture	800mm x 800mm
	Dimensions	Width / Length (W/L): 1500mm x 1445mm Thickness (T): 120mm

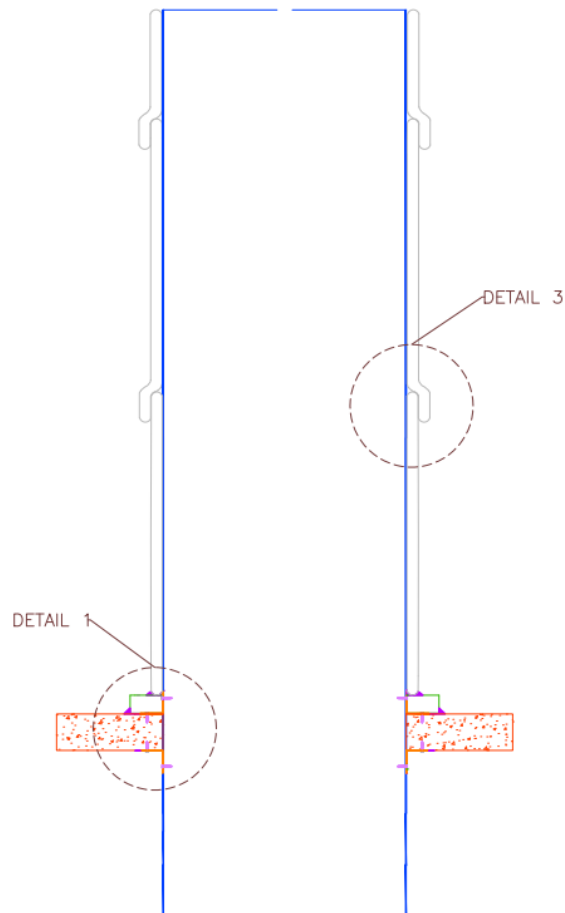

Figure 1a – Duct section view A

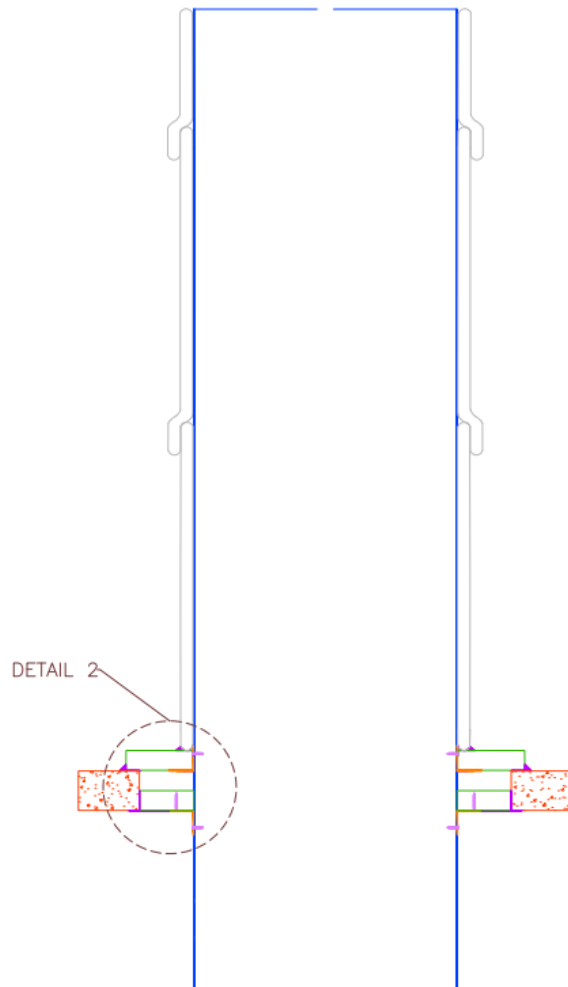

Figure 1b – Duct section view B (Section along the diagonal of separating element)

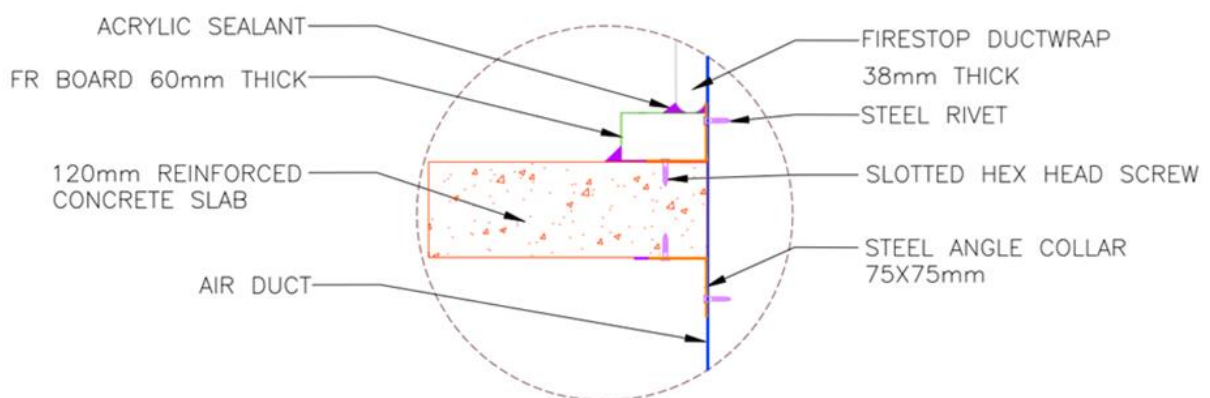

Figure 1c – Separating element detail view (from section A)

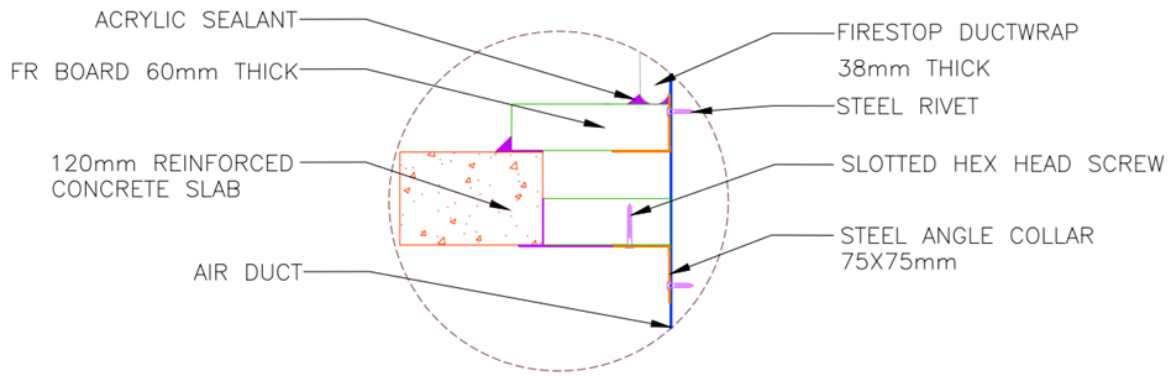

Figure 1d – Separating element detail view (from section B)

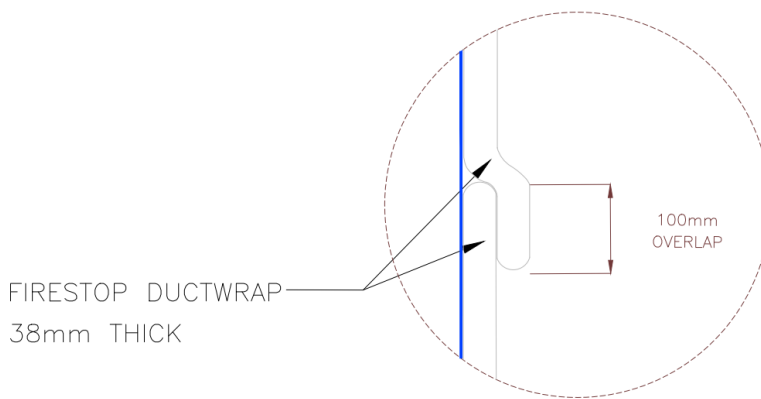

Figure 1e – Wrap overlap detail view

Specimen		
1.1	Item	Circular Air Duct
	Dimensions	Diameter (D): 800mm
	Specimen Support	Unistrut structure at 1300mm from separating element – directly fixed to the duct, protected as describe in Sections 4.2 and 4.3
	Aperture Size	800mm
	Annular Spacing	20-170mm
	Installation	Asymmetrical – Extends 540mm from the exposed face and 2340mm from the unexposed face. The duct was fixed using slotted steel angle collar with stainless steel rivets at 100mm centres and the steel angle was fixed to the concrete with 3 masonry screws per side. 10mm OD bead of sent was applied the angle prior to installation. Penetration was

		<p>protected using the two layer of FR Board – one install flush with exposed face within the slab aperture and second layer installed on the top of slab with 100mm overlap. The cut edges of the FR Board were painted with FR coating and all joints to board, duct and concrete were sealed with FIRESTOP Ultra acrylic sealant.</p> <p>A single layer of duct wrap was applied around the duct, featuring a nominal 100mm overlap for the longitudinal and transverse joints. The wrap was sealed to the FR board with 20x20m cone of sealant.</p> <p>Second layer for assessment purpose - 520mm wide layer of the duct wrap was installed on one side of the duct to the full length of the unexposed duct.</p> <p>Third layer for assessment purpose - 300mm wide layer of the duct wrap was installed on the top of second layer.</p> <p>The end of the duct at non-fire side was covered using a steel cap, fixed with steel rivet. A 50mm hole is drilled at the centre of the cap.</p> <p>The duct wrap was fixed with steel pins at 200mm centres. The duct was tested open on the fire side.</p>
--	--	--

Wrap		
2.1	Item	Firestop Duct Wrap – 38
	Dimensions	Width / Length (W/L): 1000mm x 5000mm
	Thickness	38mm
	Density	96 kg/m ³
	Installation	Used to wrap the Air duct and other specimens on unexposed face.

Sealants / Coatings		
3.1	Item	FIRESTOP Ultra Fire Rated Acrylic Sealant
	Dimensions	310mL tube
	Installation	Installed between separating element and slotted steel angle collar, between FR Board and Firestop

		duct wrap, Was used for the cable penetration and hatch installation.
3.2	Item	Protecta FR Coating
	Dimensions	8 Litres bucket
	Installation	Applied on uncoated edges of FR Boards.
3.3	Item	Protecta FR Board 2S
	Dimensions	Thickness / Width / Length (T/W/L): 60mm x 600mm x 1200mm
	Installation	Installed on top of Steel equal angle around the duct at unexposed face and installed in the aperture, flush with exposed face of concrete slab. Installed around the hatch.

Fixings		
4.1	Item	Slotted Steel Angle Collar
	Dimensions	W/H: 75mm x 75mm x 0.8mm Internal Diameter: 800mm
	Installation	Used to fix duct to concrete slab. 2 x collars were installed – one on each face of the separating element.
4.2	Item	Masonry Screw Hex Head
	Dimensions	14G x 45mm
	Installation	Used to fix steel angle collar to concrete slab at 100mm centres
4.3	Item	Stainless Steel Blind Rivets
	Dimensions	10 x 5mm
	Installation	Used to fix the steel angle collar to duct at 100mm centres.
4.4	Item	38mm Duct Pin
	Dimensions	Length (L): 38mm
	Installation	Used to fix single layers of duct wrap to the duct. Pins were attached to the duct using Capacitive Discharge Welder. Pins were located 50mm from the ends of each wrap, and 200mm centres around the both width and length of the duct.

4.5	Item	Aluminium Foil Tape
	Dimensions	Width: 100mm
	Installation	Used to seal all cut ends of wrap. Applied to each overlap between wrap layers. And used to fix thermocouples to specified locations.
4.6	Item	Slotted Hex Head screws
	Dimensions	6.35mm x 70mm
	Installation	Used to fix the FR board on the concrete slab on unexposed face.

4.1 Specimen 2 – TPS cable

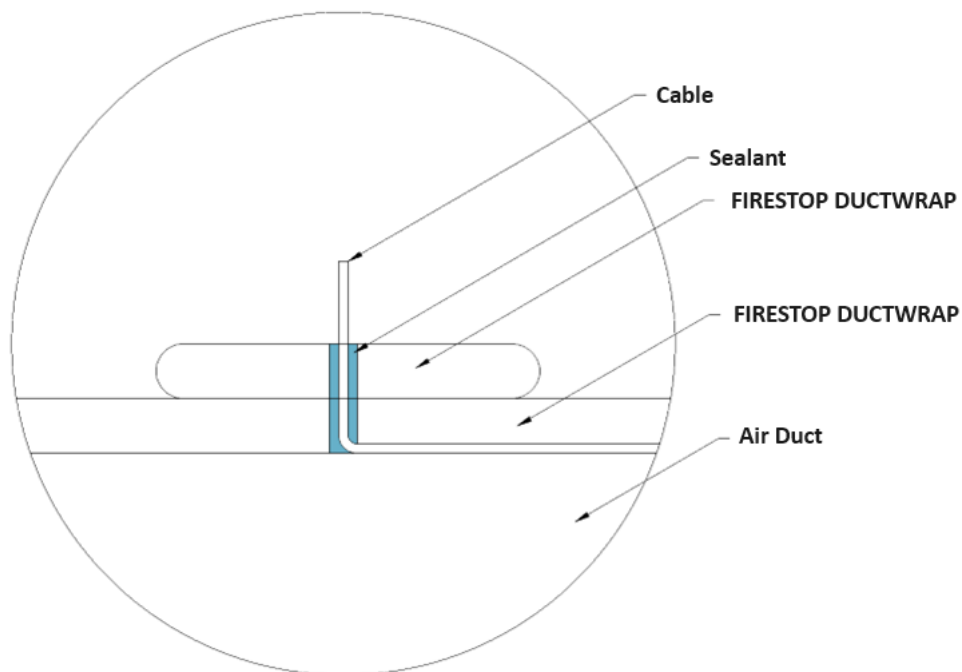

Figure 2 – Cable penetration

Specimen		
1.1	Item	2.5mm ² 2C+E Flat TPS Cable
	Dimensions	Width / Height (W/H): 12mm x 6mm
	Installation	One end of the cable was fixed to the duct. The cable penetrated one layer of the duct wrap. 200mm x 150mm patch was installed around the cable. The

		hole created by the penetration was sealed with Acrylic Sealant.
--	--	--

Tape		
2.1	Item	Aluminium Foil Tape
	Measurements	Width: 100mm
	Installation	Used to seal all cut ends of wrap. And used to fix wrap patch on the duct wrap.

Wrap		
3.1	Item	Firestop Duct Wrap – 38
	Measurements	Thickness / Width / Length (T/W/L): 38mm x 1000mm x 5000mm
	Installation	Trimmed to 200mm x 150mm patch, and penetrated by TPS Cable.

Sealants / Coatings		
4.1	Item	FIRESTOP Ultra Fire Rated Acrylic Sealant
	Dimensions	310mL tube
	Installation	Sealed the hole created by penetration.

4.2 Specimen 3 – Supporting Steel Channel

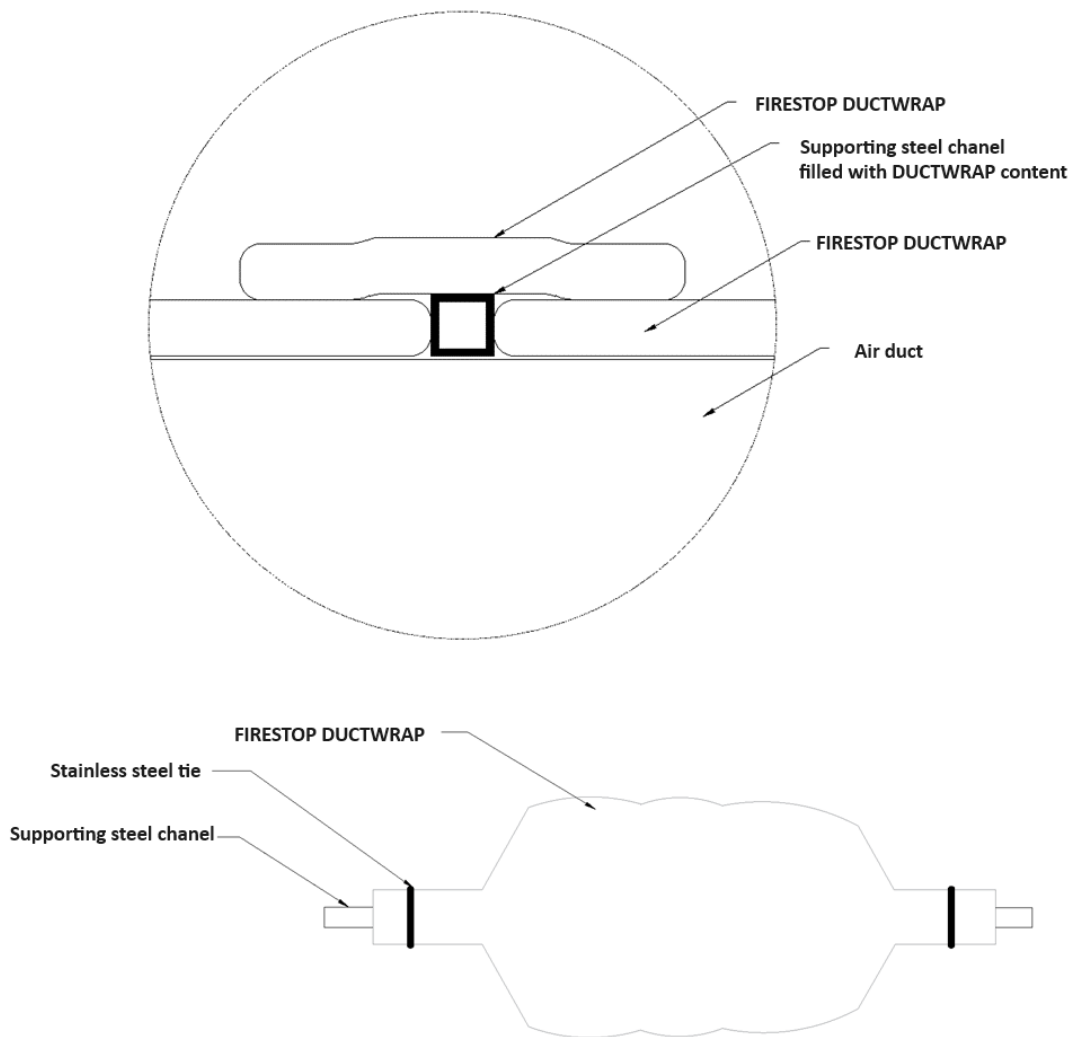

Figure 3 – Installation detail

Specimen		
2.1	Item	Supporting Steel Channel
	Dimensions	Width / Height / Thickness (W/H/T): 42mm x 42mm x 2mm
	Installation	The horizontal supporting steel channel was fixed to the duct and two additional vertical steel supporting posts. A trimmed 610mm x 1000mm wrap was used to encase the supporting channel so that the protection was wrapped around the both sides of the support by 200mm. The wrap was fixed around the support with one steel tie on each end (100mm from

		the end) and to the welded pins same way as the duct wrap. At each end of the wrap, a 100mm length of ceramic fibre was inserted into the channel.
--	--	--

Fixings		
3.1	Item	Stainless Steel Ties
	Measurements	Width / Thickness (W/T): 12mm x 3.3mm
	Installation	Used to fix the end of the duct wrap around the supporting steel channel.
3.2	Item	38mm Duct Pin
	Measurements	Length: 38mm
	Installation	Used to fix single layer of duct wrap to the duct. Pins were attached to the duct using Capacitive Discharge Welder. Pins were located 50mm from the ends of each wrap, and 200mm centres around the both width and length of the duct.
3.3	Item	Aluminium Foil Tape
	Measurements	Width: 100mm
	Installation	Used to seal all cut ends of wrap.

Wrap		
4.1	Item	Firestop Duct Wrap – 38
	Measurements	Thickness / Width / Length (T/W/L): 38mm x 1000mm x 5000mm
	Installation	Trimmed to 610mm x 1000mm and wrapped the supporting channel.

4.3 Specimen 4 – Supporting Steel Channel

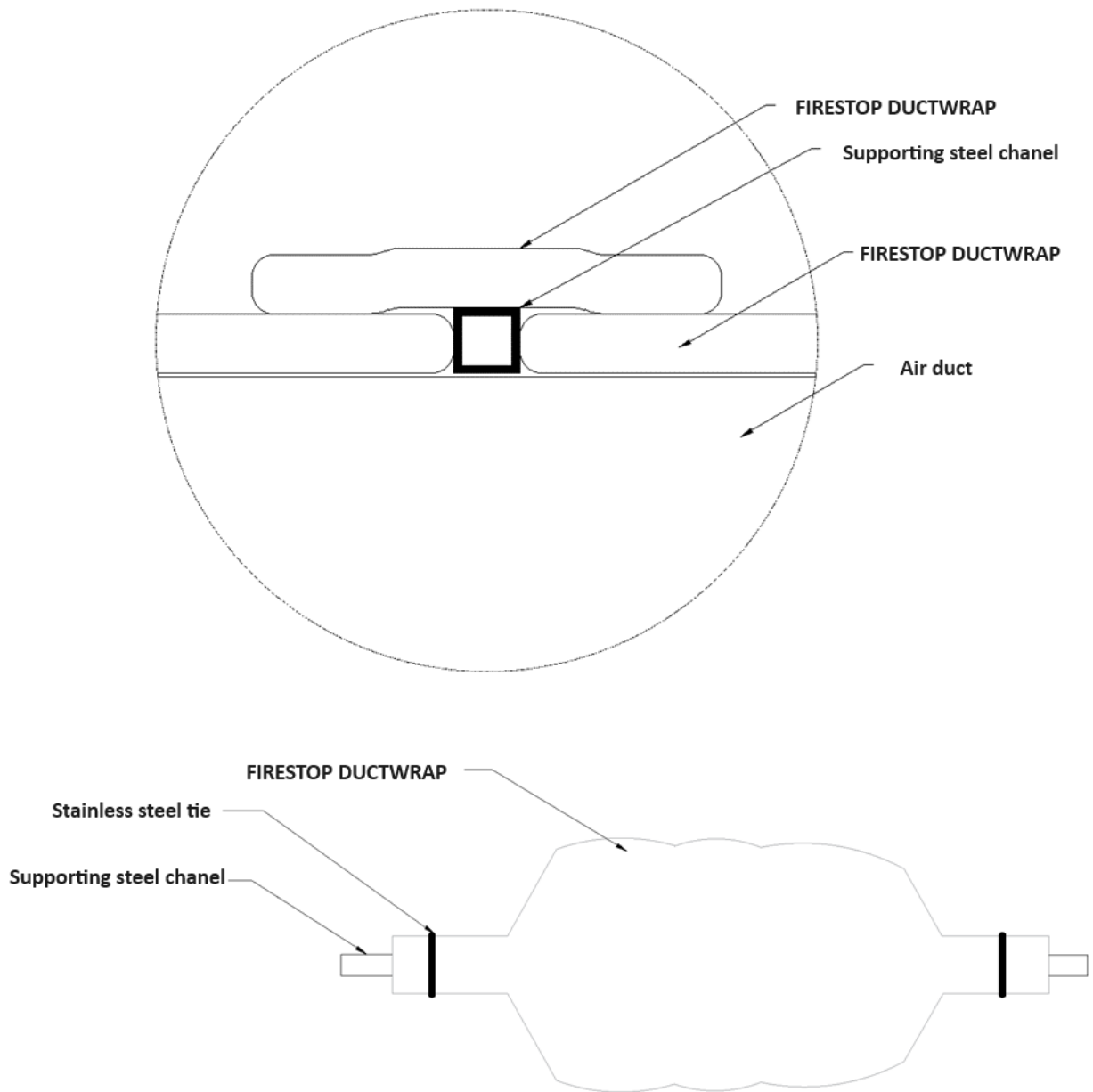

Figure 4 – Installation detail

Specimen		
2.1	Item	Supporting Steel Channel
	Dimensions	Width / Height / Thickness (W/H/T):42mm x 42mm x 2mm
	Installation	The horizontal supporting steel channel was fixed to the duct and two additional vertical steel supporting

		posts. A trimmed 610mm x 1000mm wrap was used to encase the supporting channel so that the protection was wrapped around the both sides of the support by 200mm. The wrap was fixed around the support with one steel tie on each end (100mm from the end) and with the welded pins to the duct
--	--	---

Fixings		
3.1	Item	Stainless Steel Cable Ties
	Measurements	Width / Thickness (W/T): 12mm x 3.3mm
	Installation	Used to fix the end of the duct wrap around the supporting steel channel.
3.2	Item	38mm Duct Pin
	Measurements	Length: 38mm
	Installation	Used to fix single layer of duct wrap to the duct. Pins were attached to the duct using Capacitive Discharge Welder. Pins were located 50mm from the ends of each wrap, and 200mm centres around the both width and length of the duct.
3.3	Item	Aluminium Foil Tape
	Measurements	Width: 100mm
	Installation	Used to seal all cut ends of wrap.

Wrap		
4.1	Item	Firestop Duct Wrap – 38
	Measurements	Thickness / Width / Length (T/W/L): 38mm x 1000mm x 5000mm
	Installation	Trimmed to 610mm x 1000mm and wrapped the supporting channel.

4.4 Specimen 5 – Access Hatch

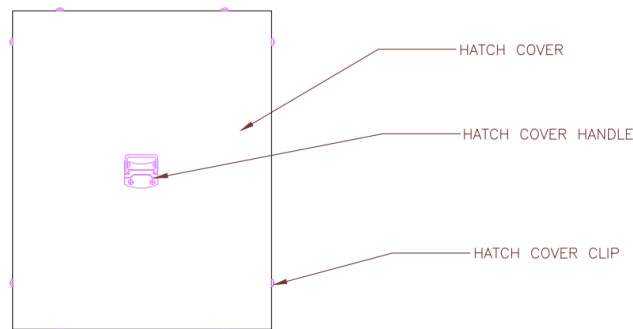

Figure 5a – Plain view

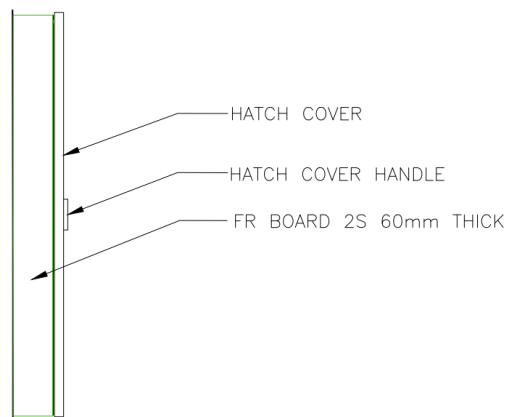

Figure 5b – Side view

Specimen		
1.1	Item	Access Hatch
	Dimensions	640mm x 520mm (nominal)
	Aperture Size	440mm x 320mm (nominal)
	Installation	<p>The hatch aperture was cut from the duct, located 880mm from the separating element. The hatch was fixed over the aperture. 10mm OD bead of sealant was applied around the aperture. The hatch was fixed to the duct using rivets at approximately 150mm centres around the hatch. Sealant was then applied to the gap between the hatch and the duct.</p> <p>FR board was trimmed to size and friction fitted to the hatch recess. All unpainted edges were painted with FR Coat and sealant was applied mid width of the collar prior to installation. The collar was fixed</p>

		<p>together using 100mm pig tail screws in every corner 30mm from the edge.</p> <p>The standard wrap protection was installed around the hatch and the joint was sealed with 10x10 cone of sealant. Second layer of the wrap was installed to one side for assessment purpose.</p>
--	--	--

Wrap		
2.1	Item	Firestop Duct Wrap – 38
	Measurements	Thickness / Width / Length (T/W/L): 38mm x 1000mm x 5000mm
	Installation	Duct wrap was fixed around the FR Board on unexposed face. An additional layer of duct wrap (870mm x155mm) was installed next to the FR Board at the left-hand side of the hatch.

Fixings		
3.1	Item	Stainless Steel Blind Rivets
	Measurements	Length / Diameter (L/D): 7.6mm x 5mm
	Installation	Used to fix the Access Hatch to duct at 150mm centres
3.2	Item	38mm Duct Pin
	Measurements	Length: 38mm
	Installation	Used to fix single layer of duct wrap to the duct. Pins were attached to the duct using Capacitive Discharge Welder. Pins were located 50mm from the ends of each wrap.
3.3	Item	Protecta FR Board (Ribbed) 2S
	Measurements	Thickness / Width / Length (T/W/L): 60mm x 600mm x 1200mm
	Installation	Trimmed to fit into the gap between duct and the hatch cover.
3.4	Item	Pig tail screws
	Measurements	100mm
	Installation	Used to fix FR Board around the hatch

Sealants / Coatings		
4.1	Item	FIRESTOP Ultra Fire Rated Acrylic Sealant
	Dimensions	310mL tube
	Installation	Sealant was applied between the duct and hatch. Sealant was then applied around the interface of the hatch and the duct and between the FR Board collar and the wrap.



5. Additional temperature measurements

Additional thermocouples were installed to assess the performance of the duct wrap protection at different distances from the separating element.

Layers of wrap	From the board, mm	Maximum temperature rise, deg C			
		30 min	60 min	90 min	120 min
1	25	126	257	267	307
	400	202	-	-	-
	900	191	212	227	237
	1600	94	187	196	202
	2100	93	175	168	173
2	25	33	94	137	168
	400	37	138	146	155
3	25	18	36	59	87
	400	7	53	106	128

Additional thermocouples were installed to assess the performance of the Access hatch with one and two layers of the wrap around – 25mm from the hatch collar.

Item	Maximum temperature rise, deg C			
	30 min	60 min	90 min	120 min
Hatch	49	91	130	143
1 layer of wrap	118	241	268	283
2 layers of wrap	41	67	118	143

6. Permissible variations to the tested specimen

A test result obtained for the largest air duct in the range may be applied to all air ducts of the same type (including any aspect ratio), provided the maximum dimensions do not exceed those tested and that the components remain in the same orientation as that tested.